

Bøjning

BU 60°

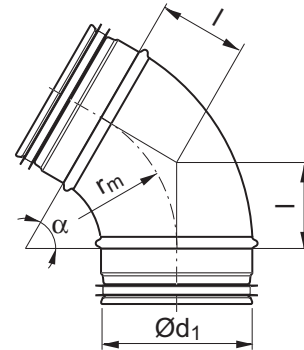

Dimensioner



$$r_m \approx 1 \cdot d_1$$

Beskrivelse

Presset, trådsvejset og kalibreret.

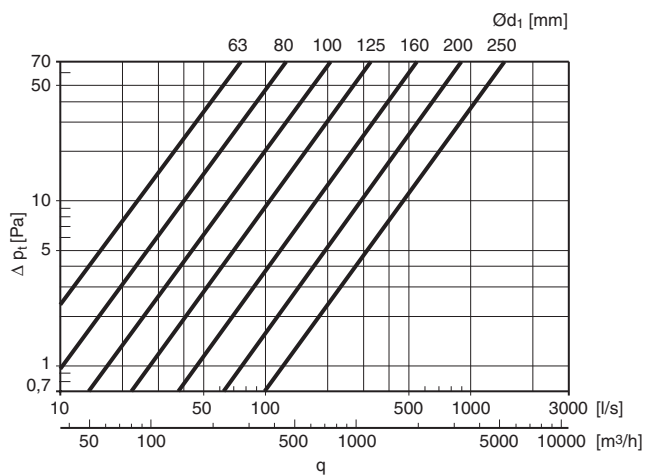

O_{d_1} nom	l mm	m kg
63	64	0,30
80	58	0,32
100	58	0,33
125	72	0,33
160	92	0,56
200	115	0,82

Bestillingskode

